

Observatory system

John Hicks

GlobalNOC, Indiana University

Takatoshi Ikeda

APAN-JP, KDDI Labs

Outline

- Brief description of an Observatory system
- Why do we need a persistent system
- Deployment of the Observatory

Brief description of Observatory system

- The word "Observatory" is borrowed from the Internet2 "Abilene Observatory" system.
- The goal of this effort is to provide valuable data and tools to network engineers and researchers in order to debug network problems and improve application performance.
- Providing an Observatory framework will help determine the performance characteristics of the complete path by aggregating information about the segments that make up the network path.

Brief description of Observatory system (cont.)

- The Observatory system consists of PCs deployed at key location along the network backbone collecting and analysing measurement data.
- This work makes use of existing tools such as Internet2s bwctl and owamp codes.
- Other tools from the Abilene NOC, APAN NOC JP, and NLANR may also be deployed on this hardware.
- The collect data is made publicly available.
- Basic authentication is also provided.

Why do we need an Observatory

- An Observatory system is needed at key locations along the network backbone in order to perform partial path analysis of network segments.
- Partial path data analysis provides a finer grained view of performance issues to network administrators and application engineers.
- Providing a persistent measurement infrastructure gives a consistent view of network performance.
- Regularly scheduled and on demand testing are accomplished using this infrastructure.
- Making the data and tools publicly available opens the door for easy data access.

Deploying APAN Observatory

- Takatoshi Ikeda visited Indiana University in December 2004 to work on Observatory code including bwclt, owamp, and netflow flow-tools.
- Measurement machines were installed at Indiana University (IUPUI in Indianapolis).
- Currently measuring from Indiana to Tokyo over the JGN2 link in Chicago.
- SNAPP and other Global NOC tools are being deployed to support data collection and analysis.
- APAN SNAPP implementation:
<http://nms2.jp.apan.net/cgi-bin/snapp/index.cgi>

TransPAC2 Measurement goals for the first year

- Measurement machines will be deployed in the TransPAC2 U.S. co-location space to collect data (some resources already located in Tokyo).
- Full code implementation of existing measurement and analysis tools.
- Schedule persistent tests between APAN/TransPAC2 and Abilene Observatory nodes.
- Make measurement data available to the network and research communities.
- Foster collaboration between the APAN measurement community and other global network measurement projects.

Current deployment plan

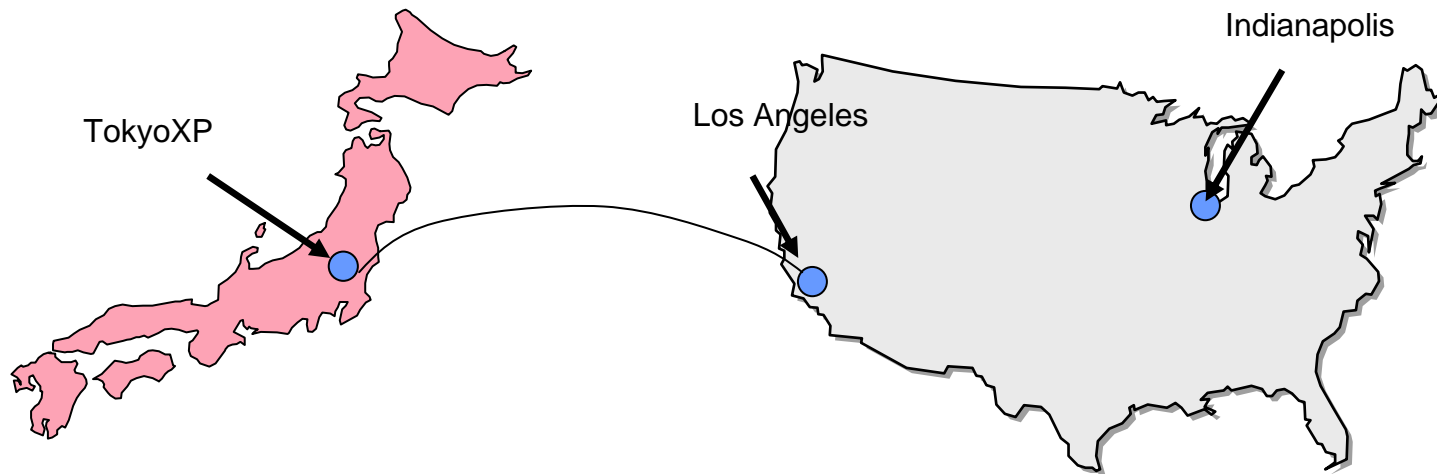

Takatashi Ikeda

KDDI labs Japan



Deployment of the Observatory

Current deployment

Location

- Japan
 - Tokyo XP
- U.S.
 - Indianapolis IUPUI

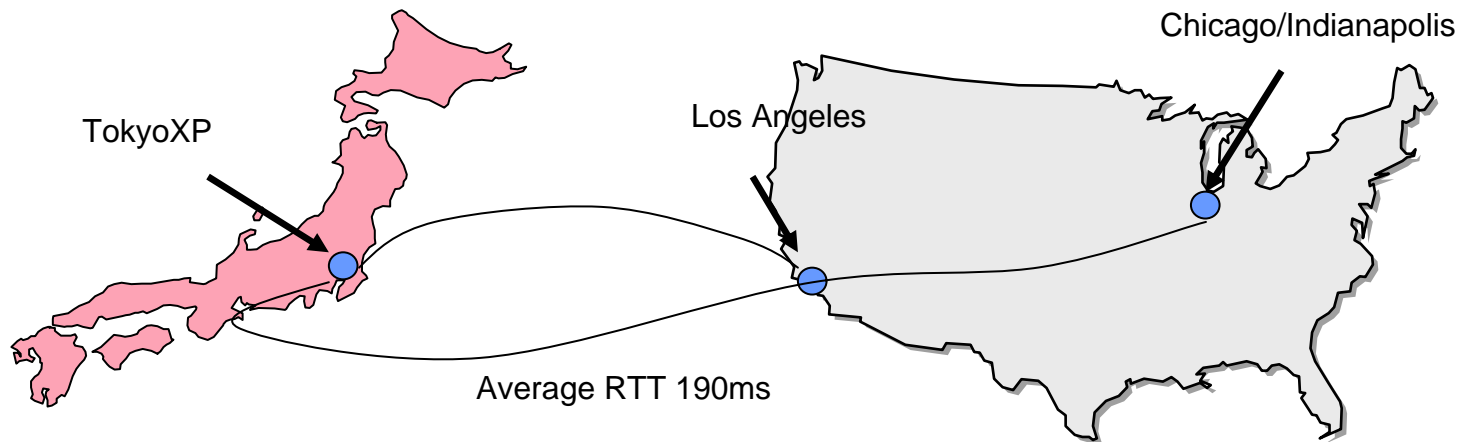

Network Diagram between NMS servers

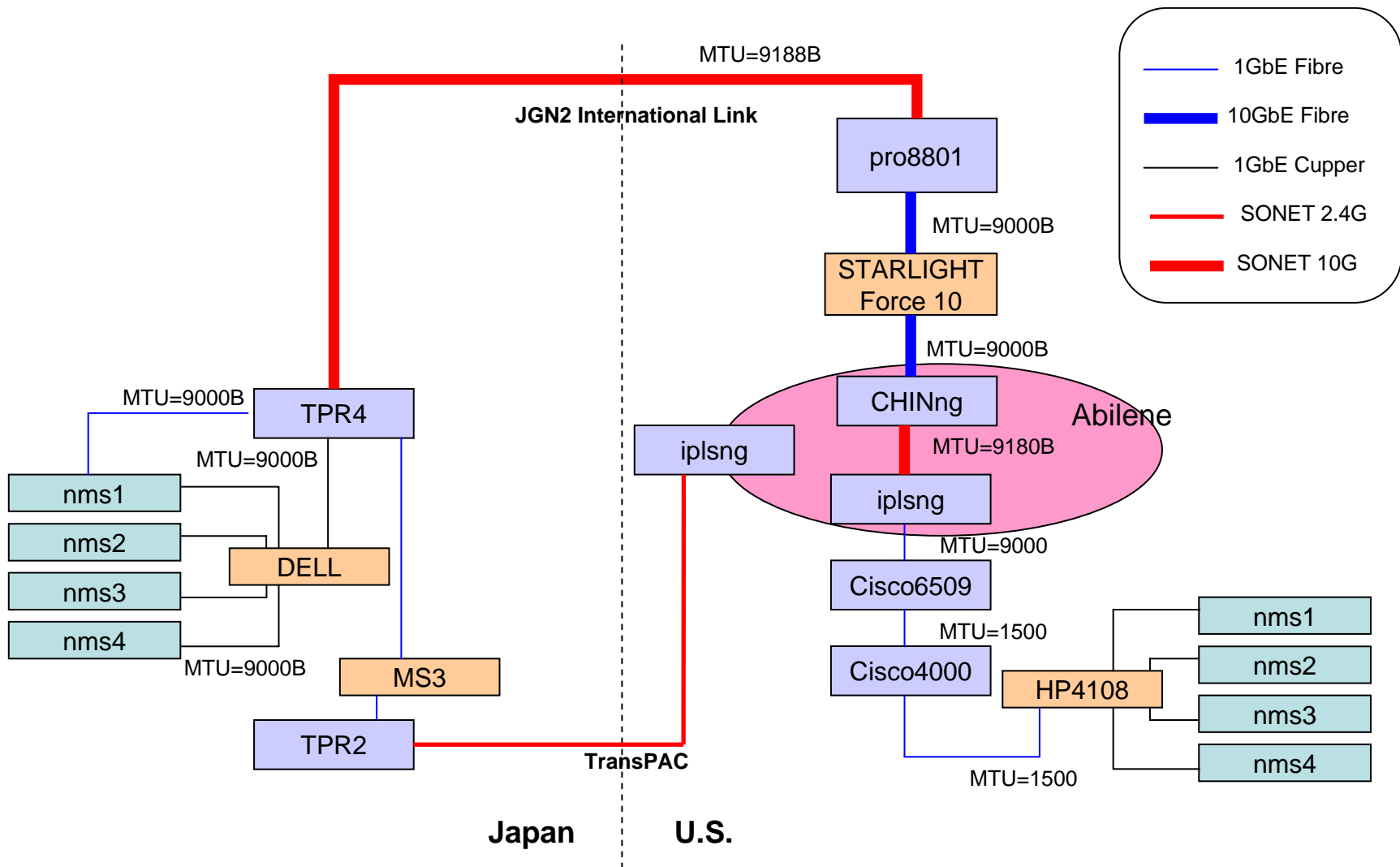

Implement

This table shows the data set and status of implement

Data set	Tools	machine	implement
Throughput	Iperf BWCTL	nms1	Available to do the throughput test on demand
One-way Latency	OWAMP	nms4	Available to measure the one-way delay on demand
netflow	flow-tools rsync	nms3	Has collected the netflow data at Tokyo XP. The data is available for the research community with authentication.
usage	net-snmp SNAPP	nms2	Available a Hi-resolution data of a usage statistics of routers at Tokyo XP.
Router	-	-	-
Routing	-	-	-
Syslog	-	-	-

Example of available data

- Netflow

The traffic graphs of major port on security are generated from this netflow data.



<http://vabo1.jp.apan.net/flow/>

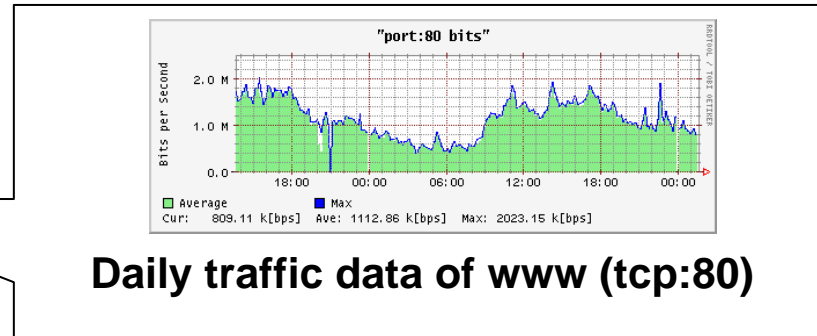

Daily traffic data of www (tcp:80)

- Usage data

The files of data can be downloaded and the graphs are available

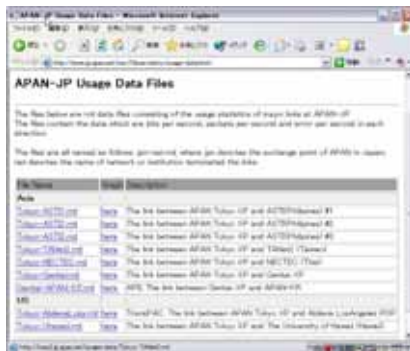

<http://www.jp.apan.net/noc/Observatory/usage-data.html>

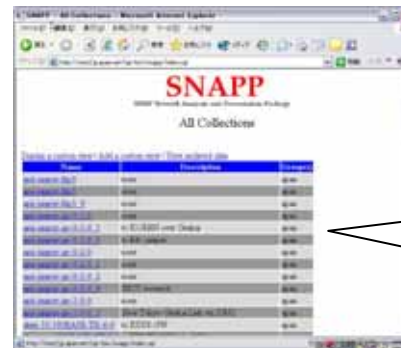

<http://nms2.jp.apan.net/cgi-bin/snapp/index.cgi>

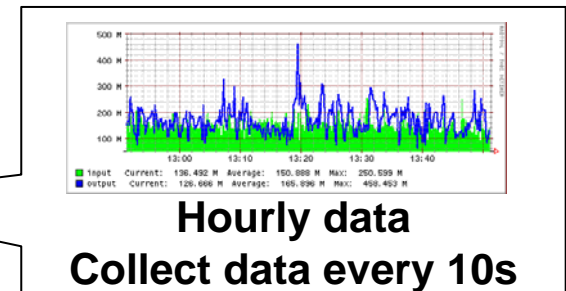

Utilization of Observatory

- Throughput
 - Connect with Abilene Observatory
 - It was used to find out the network degradation at SC2004
 - It can be used to measure the throughput performance with users
 - we used it when some users connected to Tokyo XP
- Netflow
 - The data can be used to analyze the traffic in detail.
(per protocol, port, IP address, AS,,etc)
 - The netflow data is available using rsync for the research community.
- Usage
 - The graphs of the Hi-resolution data are helpful to grasp the burst traffic in demonstrations and experiments.
 - The Hi-resolution usage data of major links are available.

Deployment plan across the TransPAC2

Network Diagram

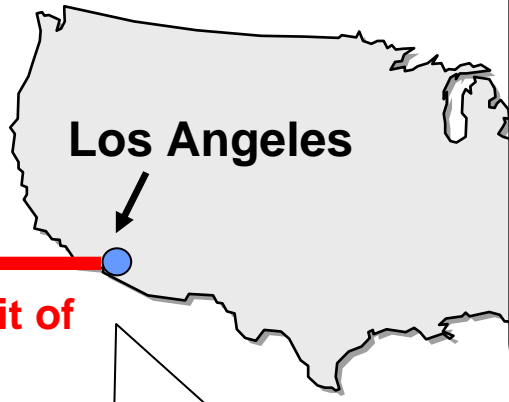
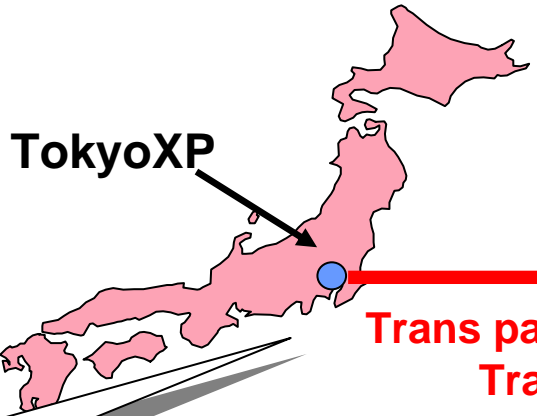

Trans pacific circuit of TransPAC2

- 1GbE Fibre
- 1GbE Copper
- OC192c
- L2 device
- L3 device
- server

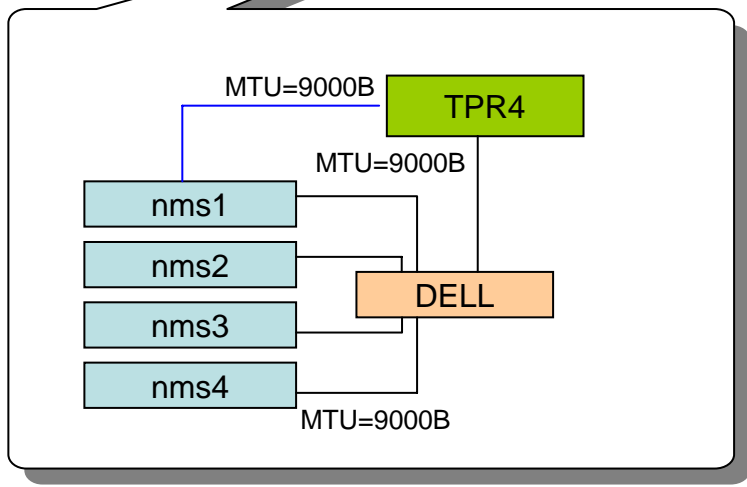

Japan

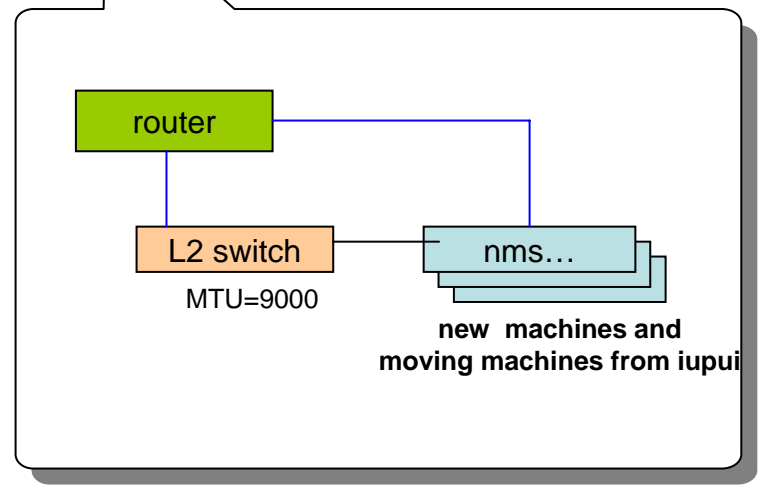

U.S.

Collected data

We will also collect the same data of current implement.

- across the TransPAC2 circuit.
 - Throughput
 - One-way Latency
- At each node
 - Netflow
 - Usage statistics
 - Router
 - Routing
 - Syslog

Scheduled Observatory for SC2005

(Plan)

Network

congestion

Observatory

data

Get the network data

Alert

detect

Notification

schedule

Unexpected user

Unexpected user

user

user

2, generate the huge traffic for experiment

Scheduled observatory

Scheduler

- Manage the schedule

manage the schedule

Monitoring tool

- Monitor the traffic
- Alert to unexpected user

Check the schedule

- 1, register the schedule
- start time, end time
 - required bandwidth
 - Src IP , Dst IP
 - ...etc

operator

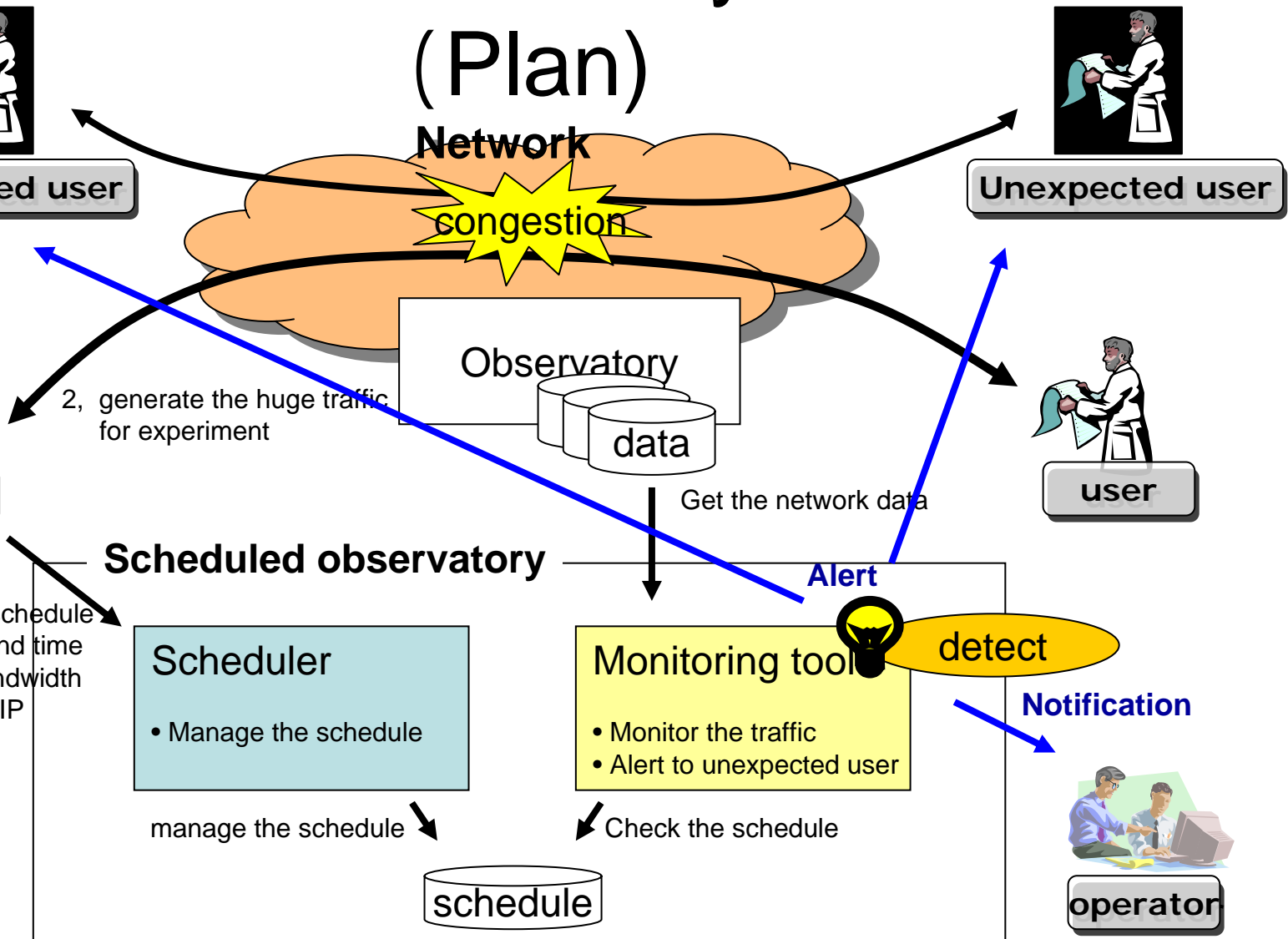

Scheduled Observatory (cont.)

- Scheduler
 - Scheduler should manage this information.
 - who generate the traffic
 - start time, end time
 - required bandwidth
 - SrcIP, DstIP, port number
 - contact point
 - .,etc
- Monitoring tool
 - Monitoring tool should monitor these data
 - Flow data (netflow)
 - Usage data of interface
 - .,etc
- Other Observatory functions for SC2005

Reference

- Abilene Observatory
<http://abilene.internet2.edu/observatory/>
- Observatory at APAN Tokyo XP
<http://www.jp.apan.net/NOC/Observatory/>
- TransPAC2
<http://www.nsf.gov/awardsearch/showAward.do?AwardNumber=0441096>
- Iperf
<http://dast.nlanr.net/Projects/Iperf/>
- BWCTL
<http://e2epi.internet2.edu/bwctl/>
- OWAMP
<http://e2epi.internet2.edu/owamp/>
- SNAPP
<http://tools.globalnoc.iu.edu/snapp.html>
- Flow-tools
<http://www.splintered.net/sw/flow-tools/>

Thank you