

GLIF

Akira Kato

WIDE

Univ. of Tokyo/WIDE Project
kato@wide.ad.jp

Background

- ☆ **Recent scientific networking needs**
 - Huge amount of data transfer
 - Long distance spanning multiple countries
 - (semi-)realtime transfer
- ☆ **TCP may not work well**
 - "fairness" cause a bottleneck
- ☆ **People want to use "dedicated lines"**
 - Fairness is not a concern
 - Aggressive retransmission is possible
 - Efficiency is reduced, however
 - Still work for residual error
 - 10^{-10} ... 10^{-12}

Lambda Networking

- ☆ **With DF+DWDM**
 - Dedicated lightpath is available
 - Mostly domestically
- ☆ **Long-haul, International**
 - Large BW links available
 - OC-48 through OC-192
- ☆ **It is possible to assign some BW dedicately**
 - GbE (OC-24), OC-48 or even OC-192
- ☆ **It is better to configure LW in end-to-end basis**
 - No packet loss at intermediate nodes
 - Due to congestion
 - Jumbo frame is possible
 - International Collaboration is necessary

Global Lambda Integrated Facility



- <http://www.glif.is/>
- A virtual organization
 - No formal by-law
- Annual invitation-only meeting
 - Aug 2004 : Reykjavik, IS
 - Sep 2004 : Nottingham, UK
 - Sep 2005 : San Diego, US
 - Sep? 2006 : Tokyo?, JP
- Intermediate meeting for TEC WG is planned
 - Feb 2005 : Salt Lake City, US

Global Lambda Integrated Facility

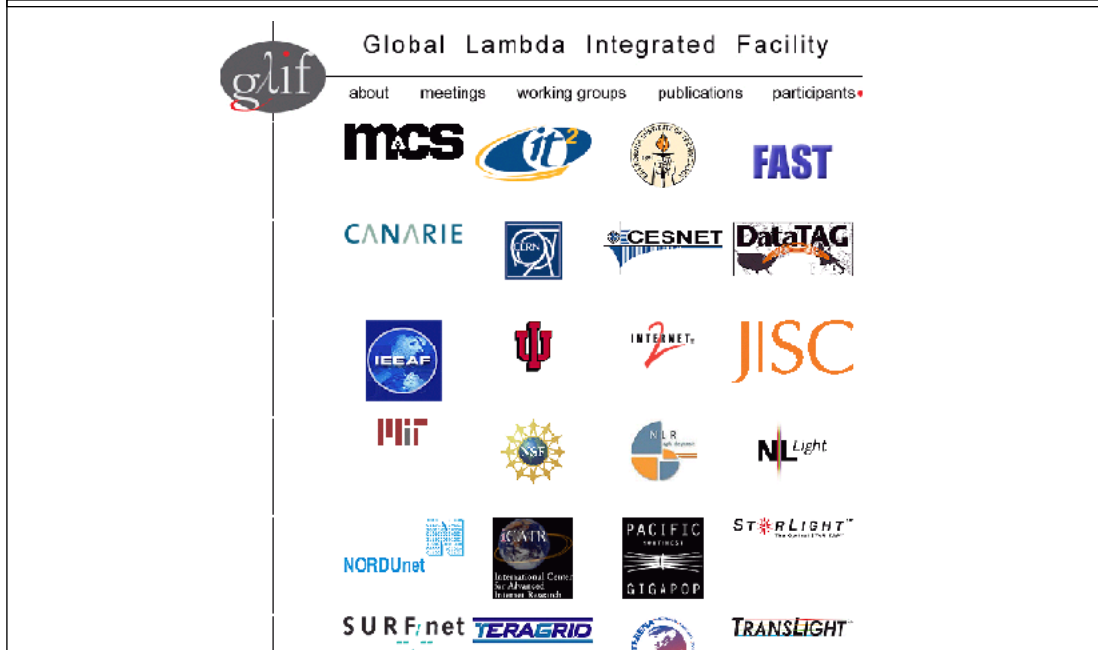

The image shows the header of the Global Lambda Integrated Facility (GLIF) website. On the left is the GLIF logo. To its right is the text "Global Lambda Integrated Facility" followed by navigation links: "about", "meetings", "working groups", "publications", and "participants". Below this is a grid of logos for participating organizations, including MCS, IT, FAST, CANARIE, CERN, CESNET, DataTAG, IEEAF, IUPUI, INTERNET2, JISC, MIT, NLR, NLLight, NORDUnet, ICATN, PACIFIC, STARLIGHT, SURFnet, TERAERID, and TRANSLIGHT.

Global Lambda Integrated Facility

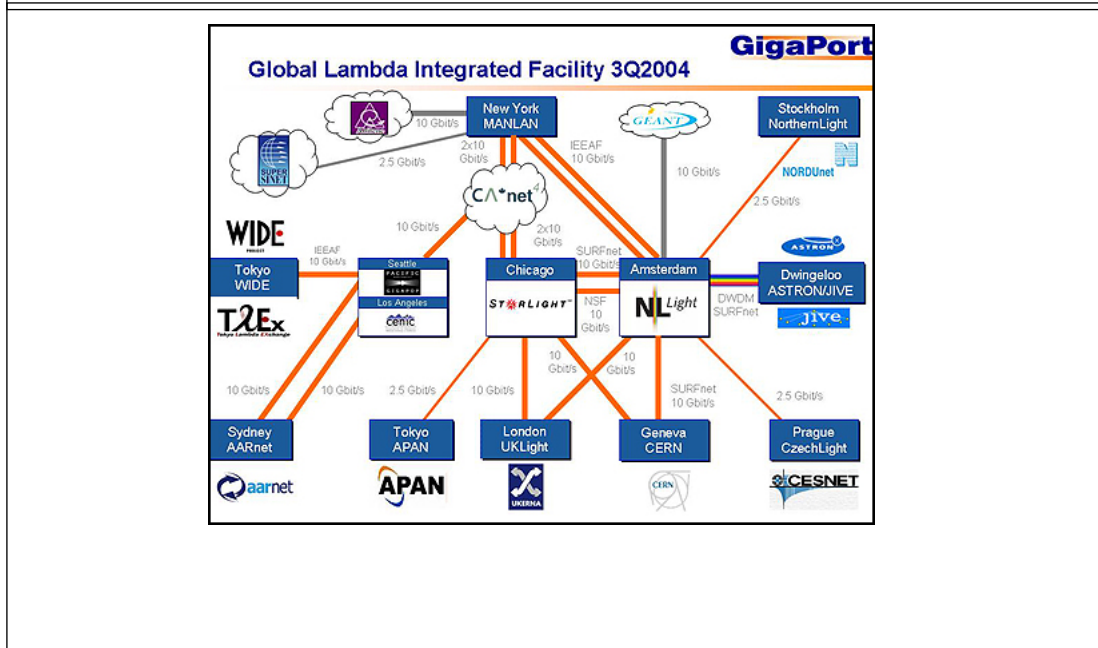

Sep 2004 : Tokyo -- Geneva OC-192

☆ Multi-national collaboration : JP, US, CA, NL, CH

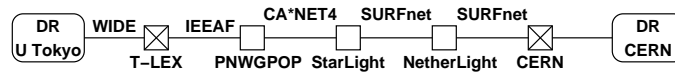

- 11,000mi/18,000km long
- L2 device: NI40G in T-LEX and CERN
- First long-distance 10GE WANPHY

☆ Data Reservoir by Prof. Hiraki filled the pipe

- Details will be given by him

Sep 2004 : Tokyo -- Geneva OC-192

☆ Circuit setup

- Configuration has been done in a day

☆ Packet loss

- SURFnet OC-192 card in Chicago was broken
 - needed another day to replace it
- Optical Attenuator at ONS-15454 OC-192 LR card
 - special SC connector (with a shutter)
 - need to put in the other end of patch
- Clock source issue
 - IEEAF OC-192 doesn't provide clocks
 - Tokyo ONS-15454 took a clock from OC-12

Sep 2004 : Tokyo -- Geneva OC-192

☆ When to work?

- Time difference is a big issue

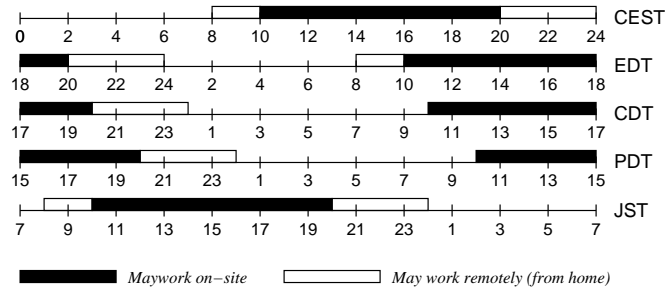

- Hard to find a "common" working hours
 - Even if primary care available in 24x7 basis
 - Senior engineers are not available in 24x7

Sep 2004 : Tokyo -- Geneva OC-192

☆ Email was used for communication

- Good
 - Asynchronous, Recorded
 - Photo, drawing, URL
- Bad
 - Non-realtime, need a separate trigger
 - SPAM protection can delay the delivery
 - Difficult to tell "subtle" things

☆ May need a sophisticated method

- International Trouble Ticketing System?

Sep 2004 : Tokyo -- Geneva OC-192

☆ Providing access to boxes helped a lot

- Mutual R/O access to ONS15454
 - UW and T-LEX
- DR got access on NI40G's in both ends
 - Realtime reading of error counters

☆ Making it to public may involve a security issue

- May need to establish a "Trustworth" community
- Access to every gear en-route should be provided
- Abilene's Core Node Proxy is a wonderful example
- Device independent access possible?
 - ONS-15454, OME6500, HDXc, Foundry, Cisco
 - Force10, Procket, Juniper, Hitachi/Alaxala, Fujitsu

JGN2



☆ JGN2 : Japan Gigabit Network version2

- A Nation-wide testbed network
 - Funded by MPHPT
- Version 1 was ATM based
- 10GE/GbE based JGN2 launched in Apr 2004
- <http://jgn2.jp/>
 - Not all information available
 - Not information available in English
- (partially unprotected) OC-192 to Chicago

☆ JGN Symposium held twice a year

- Jan 17-18, 2005 in Osaka

JGN Symposium

☆ Background

- Prof. Smarr from UCSD invited to give a keynote
- He was not make a trip to Japan
- He happened to be in Seattle
- Research Channel at UW get involved
- Trial for remote talk with HDTV
 - Using JGN's OC-192 circuit to Chicago
- Plan was not discussed in detail by Nov 04

☆ Uncompressed HDTV

- 1.5Gbps
- UW's implementation can stripe over two GbEs
 - No OC-48 or 10GE is necessary

JGN Symposium

☆ Intial Plan

- Two independent path for redundancy
 - Chicago route for main uncompressed stream
 - IEEAF route for backup compressed MPEG

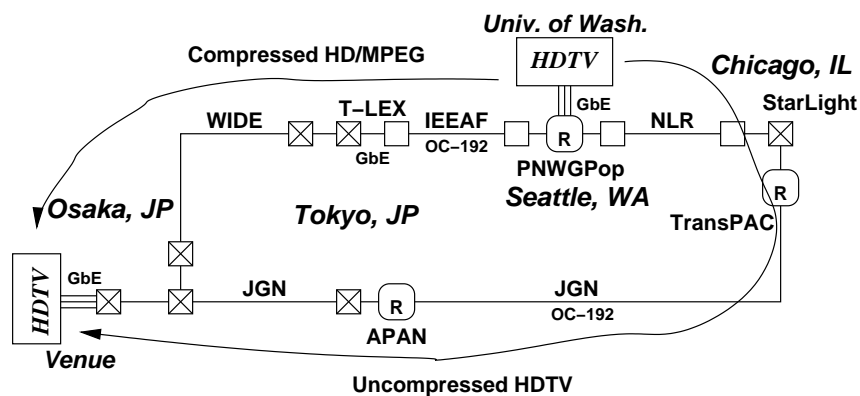

JGN Symposium

☆ A fiber cut happened in Jan10 1742JST

- Due to flooding in Nevada
- LA--Chicago JGN2 OC-192 is unprotected
- Wiltel is not able to get there until Jan11



JGN Symposium

☆ Contingency plan was being discussed

- Use IEEAF circuit for two streams
- Even after fiber restored at Jan13 1420JST
 - To avoid confusion
 - UW was busy for three demonstrations

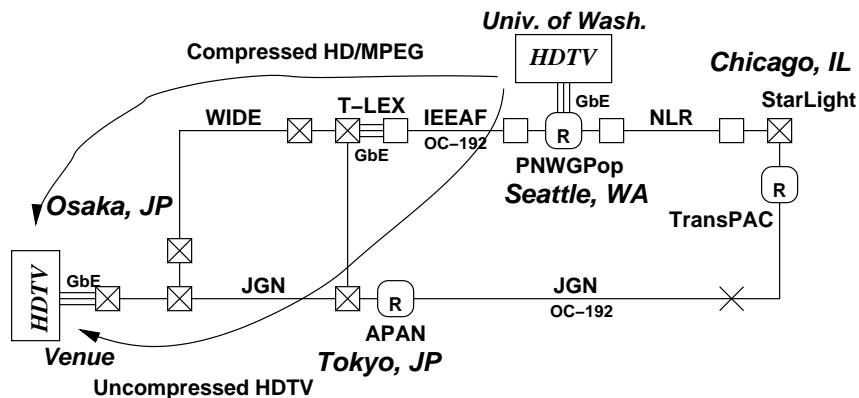

JGN Symposium



JGN Symposium

- ☆ **Prof. Smarr gave presentation in almost perfect**
 - Audio Demux broken in the last minutes in Osaka
 - Use the combination of
 - Video from the Uncompressed stream
 - Audio from HD/MPEG
 - Lip-Sync was lost, unfortunately
- ☆ **For those who involved to make this successful**
 - UW, Pacific-Interface, PNWGpop, NLW, StarLight
 - TransPAC, APAN, IEEAF, T-LEX, WIDE, JGN2
 - NTT Communications, NTT Lab, NTT West
 - and more